

NOTES:

1. PLACE TWO HALF MOON SHAPED PLYWOOD COVERS (5/8" THICK MINIMUM) ON MANHOLE SHELF AFTER SHAFTS HAVE BEEN SET TO KEEP DEBRIS FROM ENTERING SEWER UNTIL PROJECT COMPLETION & ACCEPTANCE BY DISTRICT.
2. FOR DROP MANHOLE SEE MCWD STD. PLAN S-11. DROPS OVER 1-FT REQUIRE DISTRICT APPROVAL.
3. FOR MANHOLES LOCATED OUTSIDE PAVED AREAS THE FRAME AND COVER SHOULD BE SET A MINIMUM OF 0.1 FT. ABOVE FINISH GRADE IN SHOULDER AREAS, UNPAVED ROADS OR LANDSCAPED AREAS, AND 18" IN UNFINISHED AREAS.
4. ALL INLETS AND OUTLETS SHALL BE SUPPORTED WITH CONCRETE SUPPORTS PRIOR TO POURING MANHOLE BASE.

APPROVED BY DISTRICT ENGINEER		MARINA COAST WATER DISTRICT STANDARD PLAN	STANDARD
DATE 11/2007			MANHOLE DETAILS

SEE MCWD STD. PLAN S-5 FOR
PVC PIPE CONNECTION DETAILS

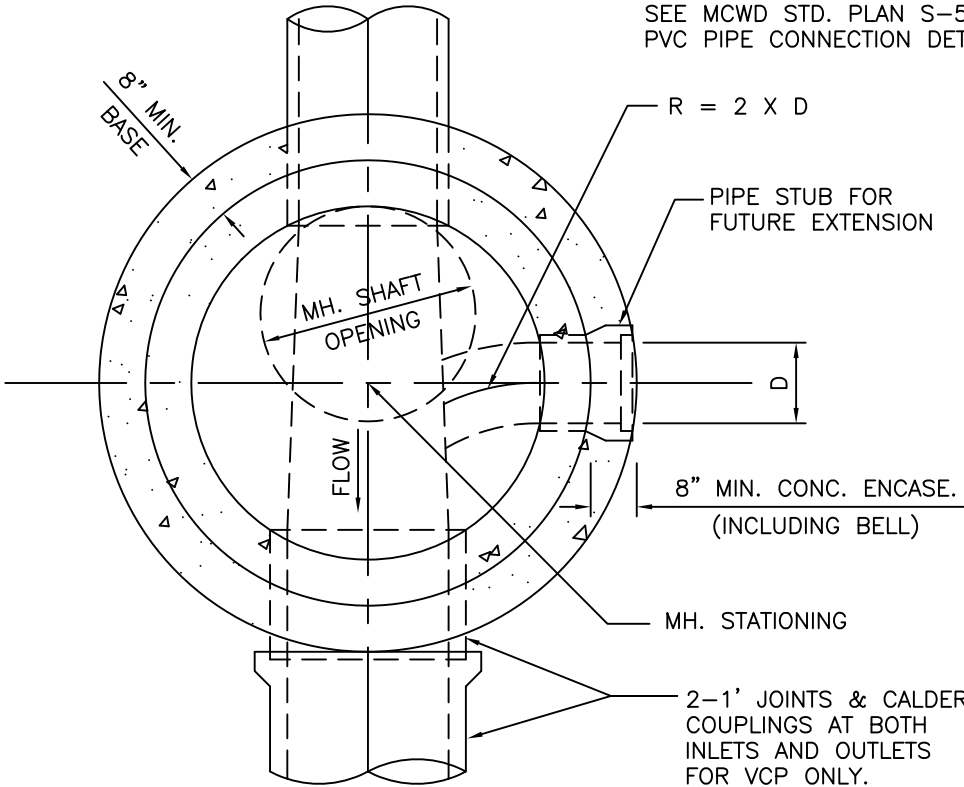

MANHOLE BASE PLAN

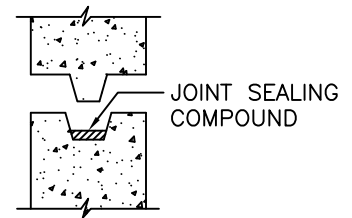

BARREL JOINT SEALANT

0.10' MIN. FALL ACROSS
MH. (TYP.) UNLESS SEWER
SLOPE GREATER. 0.20' MIN.
FALL FOR 90" MH.

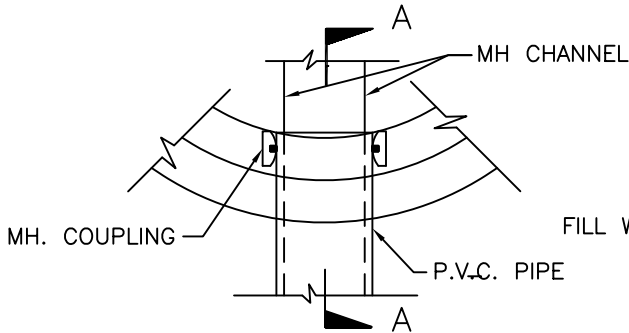

PLAN

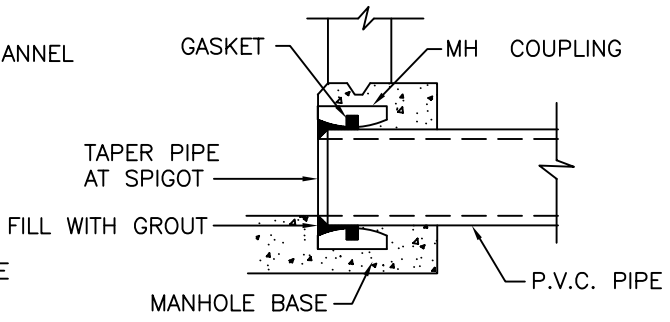

SECTION A-A

MANHOLE CONNECTION DETAILS

NOTES:

- BARREL JOINT SEALANT - PREFORMED COLD-APPLIED ELASTOMERIC PLASTIC JOINT SEALING COMPOUND SHALL BE RAM-NEK OR APPROVED EQUAL.

APPROVED BY DISTRICT ENGINEER		MARINA COAST WATER DISTRICT STANDARD PLAN	STANDARD
DATE 11/2007		<p style="text-align: center;">CONCRETE MANHOLE BASE, CONNECTION & JOINT DETAILS</p>	S-2
			SHEET 1 OF 1

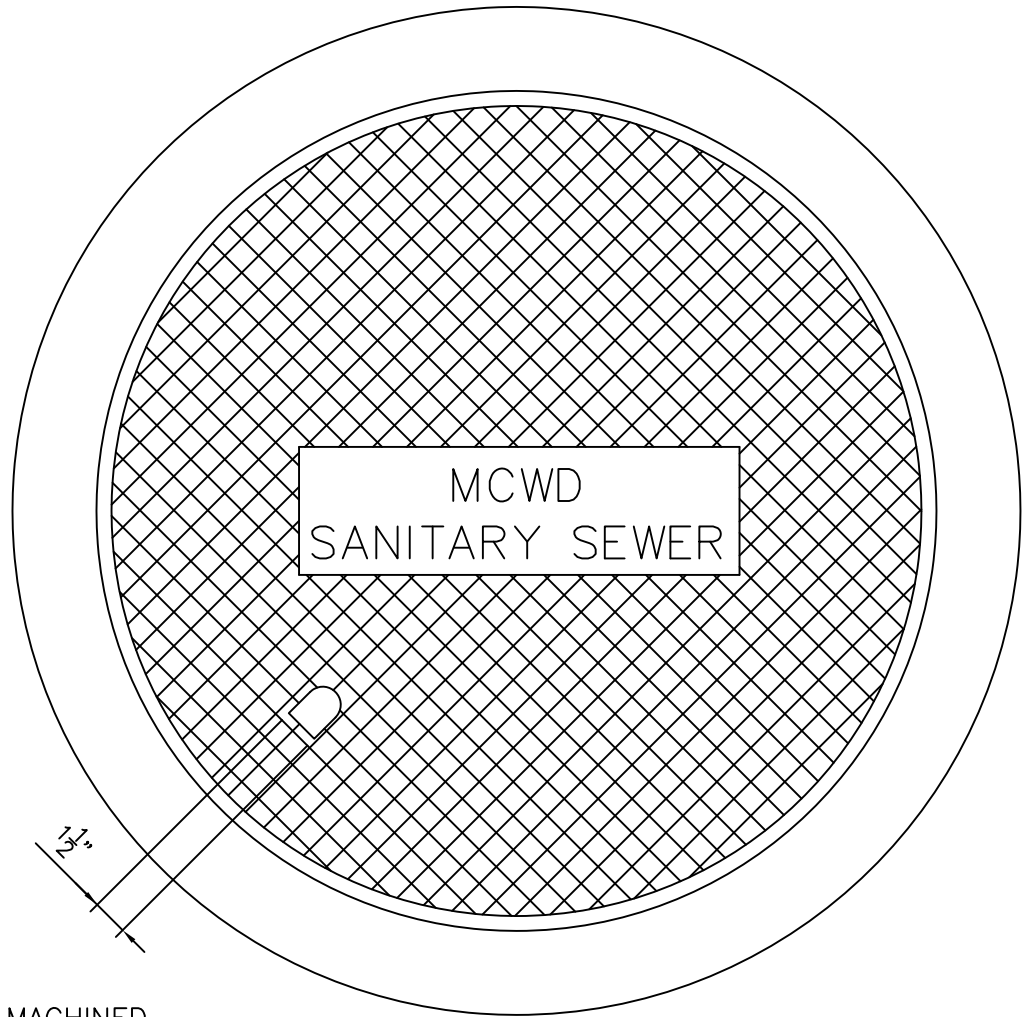

MCWD
SANITARY SEWER

13 1/2"

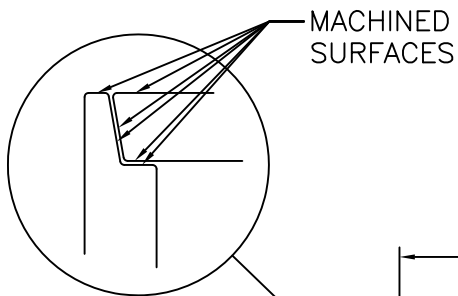

MACHINED SURFACES

CURVED BLIND PICKHOLE

SOUTHBAY FOUNDRY SFB 1900 OR EQUAL 24" FULL TRAFFIC TYPE NON ROCKING MANHOLE FRAME AND COVER. DESIGNED FOR H-20 HIGHWAY LOADING

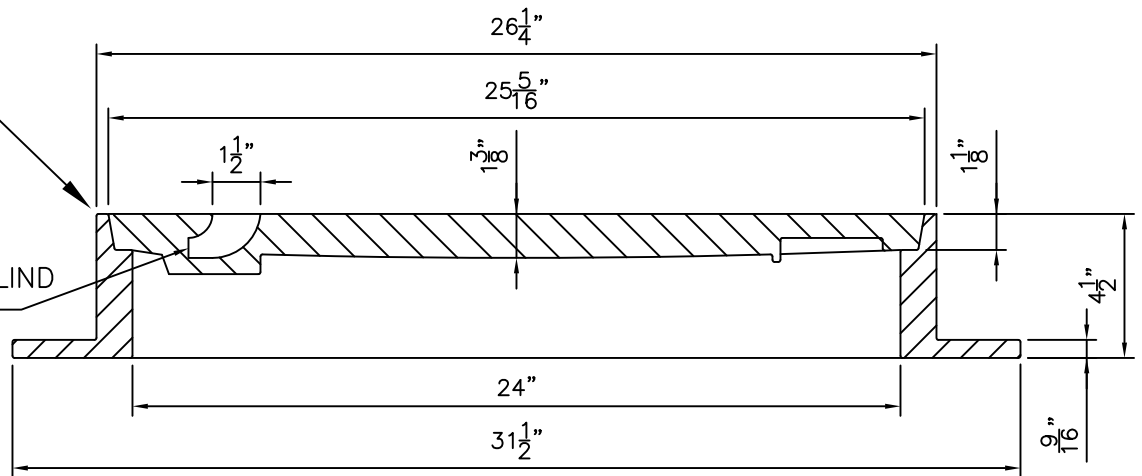

SET WEIGHT
COVER 130
FRAME 140
TOTAL 270 LBS

APPROVED BY
DISTRICT
ENGINEER

DATE
11/2007



MARINA COAST WATER DISTRICT STANDARD PLAN

TRAFFIC MANHOLE FRAME & COVER

STANDARD

S-3

SHEET 1 OF 1

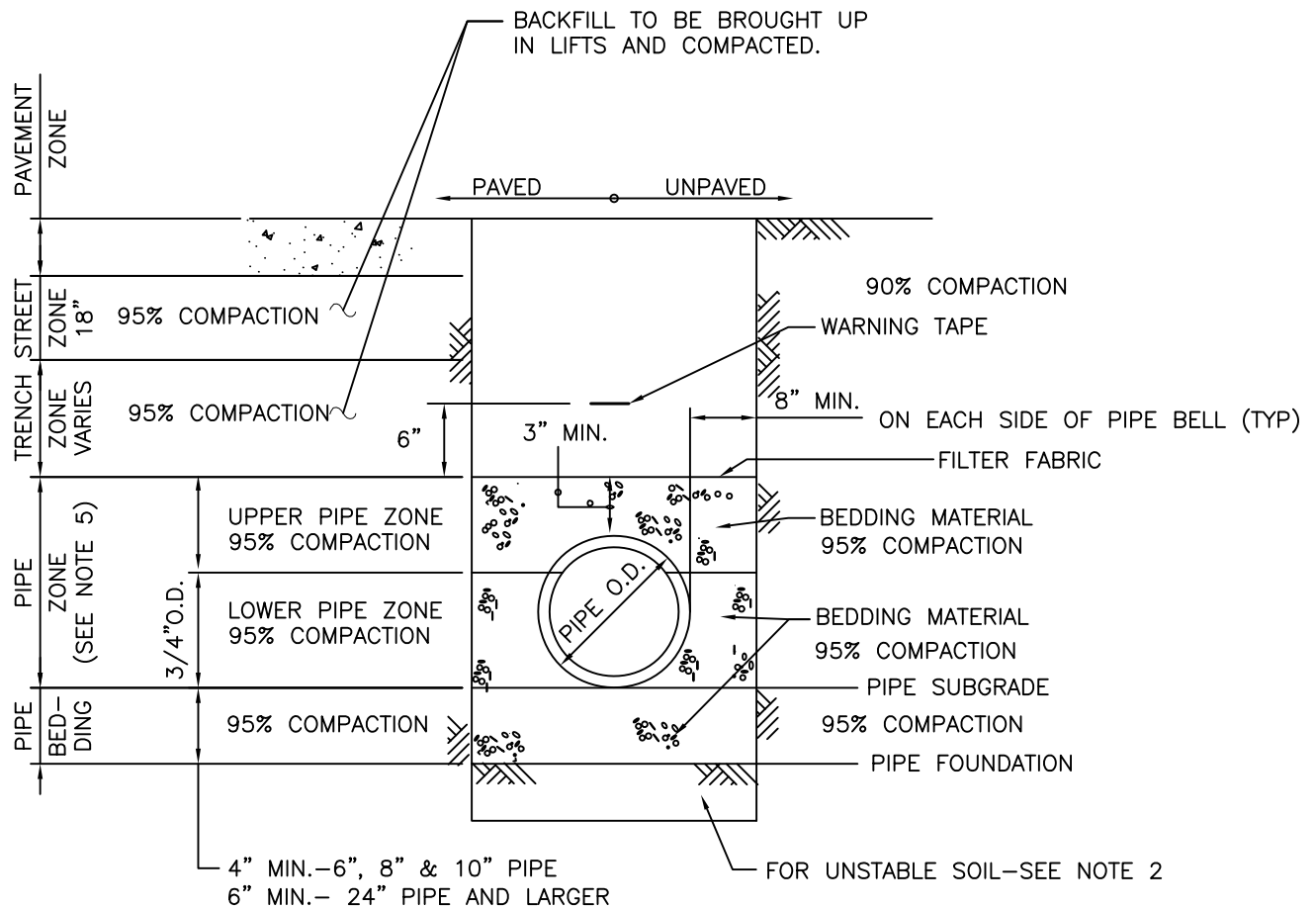

NORMAL BEDDING

NOTES:

1. CONCRETE ENCASEMENT PER MCWD STD. PLAN S-8 SHALL BE USED WHERE THE TRENCH WIDTH AT THE UPPER LIMIT OF THE PIPE ZONE EXCEEDS THE MAX. WIDTH SPECIFIED ABOVE.
2. IF UNSTABLE SOIL IS ENCOUNTERED, DISTRICT REPRESENTATIVE SHALL DETERMINE DEPTH OF REMOVAL AND SIZE OF FOUNDATION ROCK REFILL MATERIAL.
3. OVERWIDTH BEDDING SHALL BE USED WHERE THE TRENCH WIDTH AT THE UPPER LIMITS OF THE PIPE ZONE EXCEEDS THE MAXIMUM SPECIFIED ABOVE. MAXIMUM OVERWIDTH BEDDING TO BE DETERMINED IN THE FIELD BY THE DISTRICT REPRESENTATIVE ON THE BASIS OF OVERWIDTH EXCAVATED.
4. NO NATIVE BACKFILL SHALL BE ALLOWED IN THE PIPE ZONE.
5. PIPE INSTALLED MORE THAN 20' BELOW GRADE SHALL BE ENGINEERED AND SUBMITTED TO THE DISTRICT ENGINEER FOR APPROVAL.
6. THESE ARE MINIMUM REQUIREMENTS. IF OTHER JURISDICTIONAL REQUIREMENTS DIFFER FROM THOSE CONTAINED HEREIN, THE MOST STRINGENT REQUIREMENTS SHALL DICTATE.

APPROVED BY
DISTRICT
ENGINEER

DATE
11/2007



MARINA COAST WATER DISTRICT STANDARD PLAN

PVC PIPE BEDDING DETAIL

STANDARD

S-4

SHEET 1 OF 1

WHEN IN PAVED AREAS, LEAVE CONCRETE 2" BELOW FINISHED GRADE, IN OTHER AREAS SLOPE AWAY FROM INLET

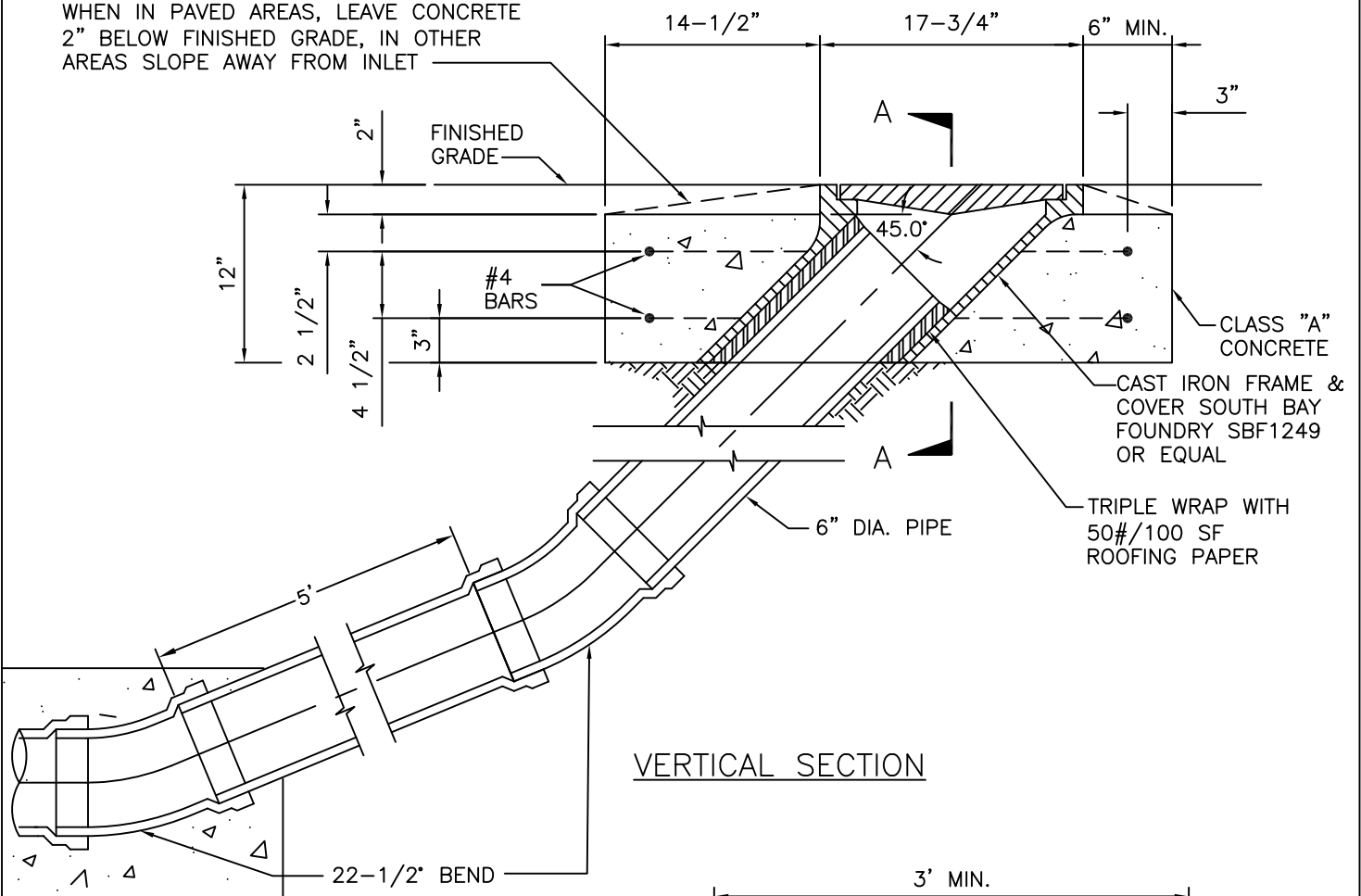

FURNISH CONCRETE THRUST BLOCK THE ENTIRE WIDTH OF TRENCH

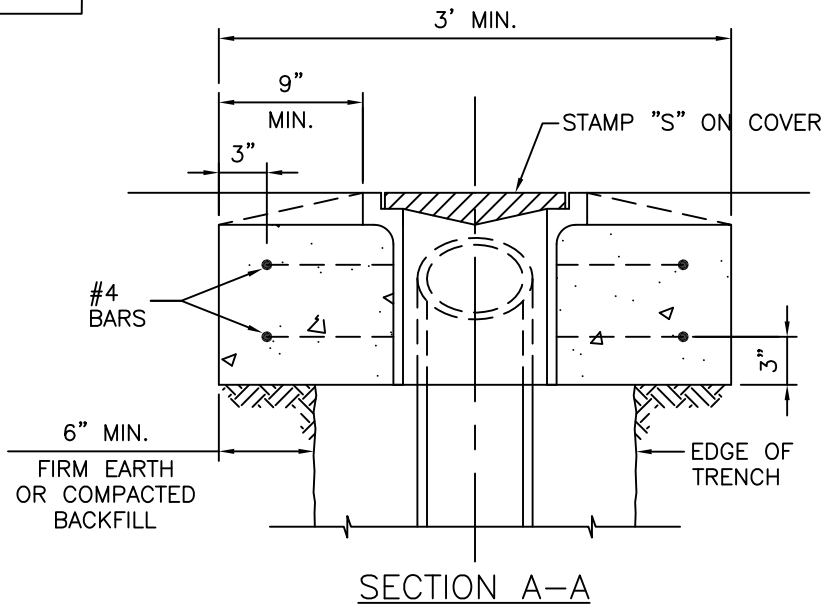

APPROVED BY
DISTRICT
ENGINEER

DATE

11/2007



MARINA COAST WATER DISTRICT STANDARD PLAN

FLUSHING INLET

STANDARD

S-5

SHEET 1 OF 1

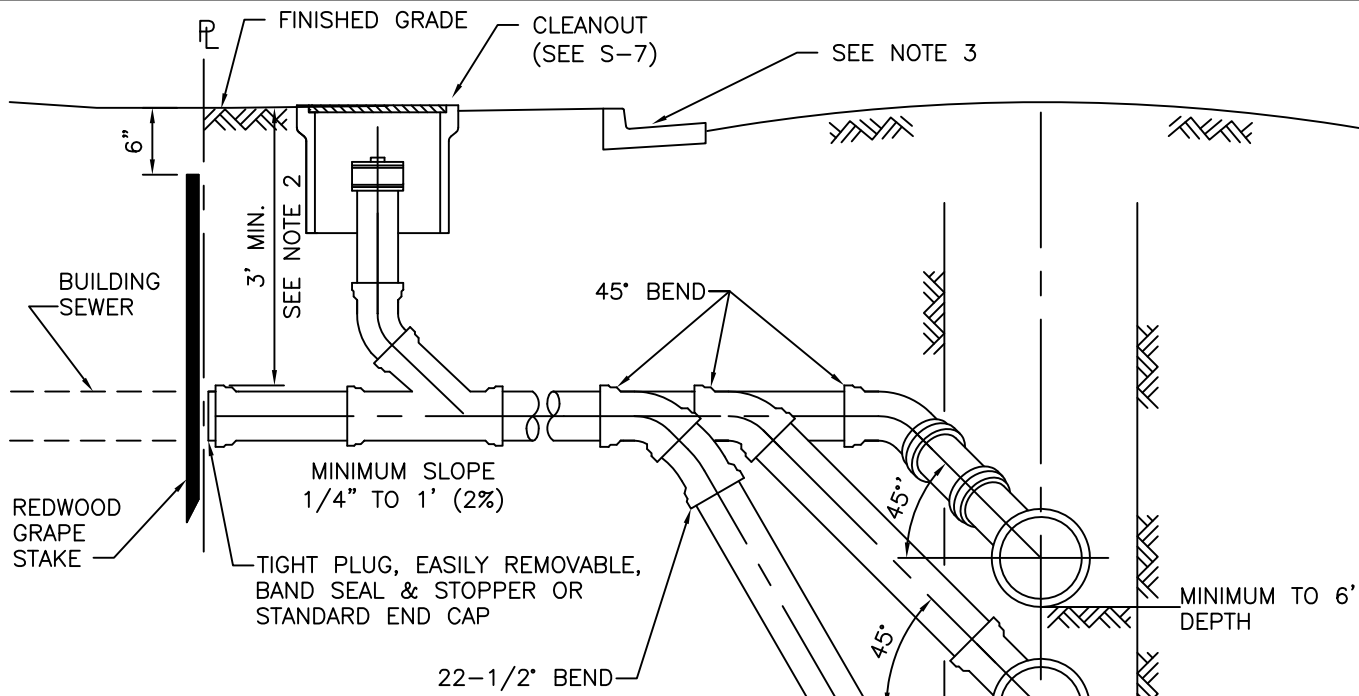

NOTES:

- 1- FOR SEWER DEPTHS FROM MINIMUM COVER TO 6 FT. USE STANDARD WYE CONNECTION. FOR DEPTHS BELOW 6 FT. USE STANDARD TEE CONNECTION WITH SLOPING RISER AS SHOWN.
- 2- WHEN SEWER IS AT MINIMUM DEPTH, HOLD SERVICE LINE TO MINIMUM SLOPE AND LESSEN COVER AT PROPERTY LINE.
- 3- THE LOCATION OF ALL SEWER LATERALS SHALL BE MARKED WITH THE LETTER "S" ON FACE OF CURB OR BACK OF WALK.
- 4- IF CONTRACTOR IS UNABLE TO MEET MINIMUM COVER REQUIREMENTS, DUCTILE IRON PIPE SHALL BE USED.
- 5- ALL SERVICE TEES OR WYES SHALL BE MANUFACTURER'S STANDARD FITTINGS. ON SERVICE ADDITIONS, TAP-RITE OR SEWER SADDLE SHALL BE USED. NO PIPE BREAKING AND CONCRETE PATCHING WILL BE PERMITTED. ONLY NEATLY SNAPPED OR SAW CUT LENGTHS WILL BE ALLOWED.

MATERIALS

SANITARY SEWER PIPE MATERIAL	CUT-IN FITTING MATERIAL
PVC	PVC/DIP
DIP	DIP
VCP	PVC
CMLC	PVC

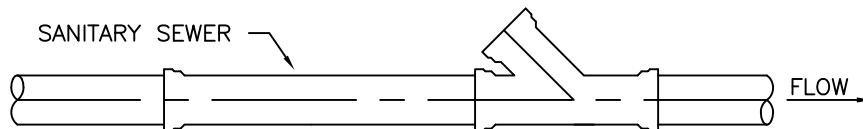

STANDARD WYE CUT-IN DETAIL

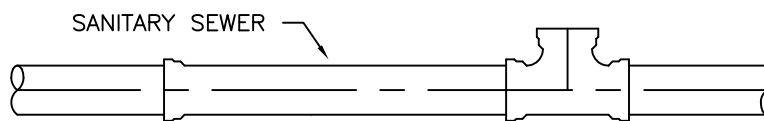

STANDARD TEE CUT-IN DETAIL

APPROVED BY
DISTRICT
ENGINEER



DATE
11/2007

MARINA COAST WATER DISTRICT STANDARD PLAN

LATERAL CONNECTION

STANDARD

S-6

SHEET 1 OF 1

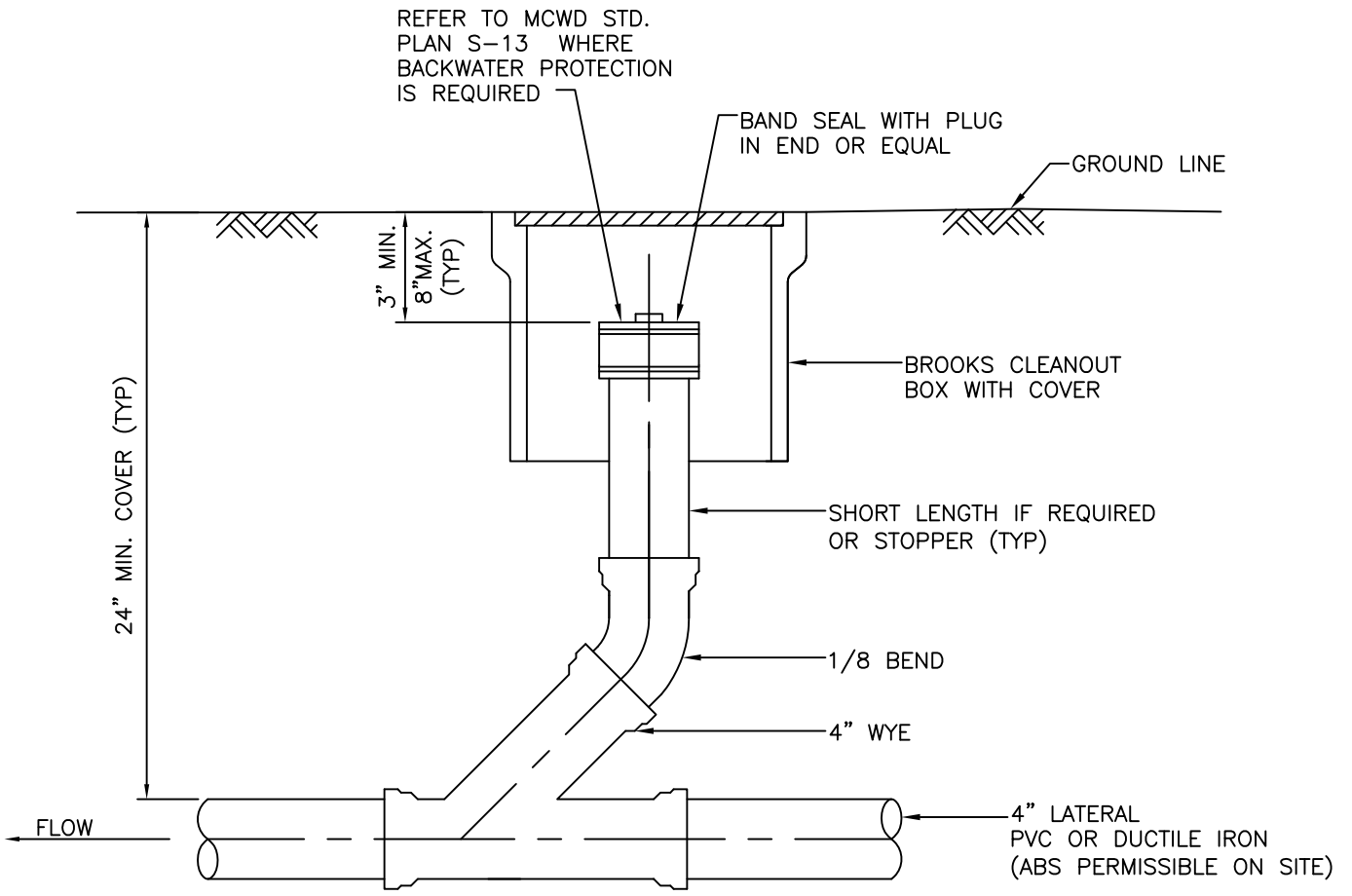

BUILDING SEWER
STANDARD CLEANOUT DETAIL SPECIFICATION

APPROVED BY DISTRICT ENGINEER		MARINA COAST WATER DISTRICT STANDARD PLAN	STANDARD
DATE 11/2007		BUILDING CLEANOUT	S-7
SHEET 1 OF 1			

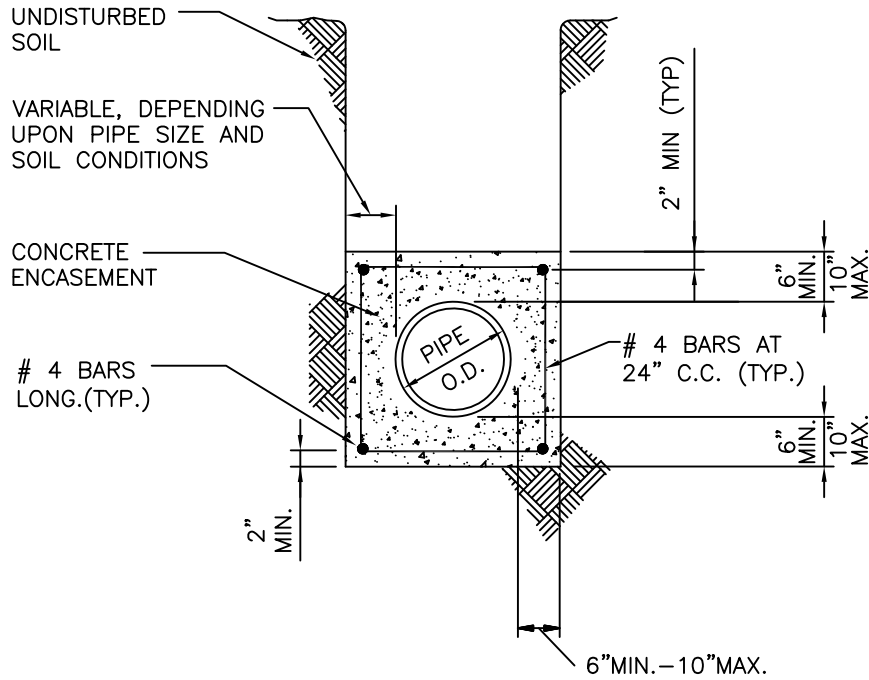

NOTES:

- 1- CONCRETE ENCASEMENT SHALL BE USED WHEN COVER IS UNDER 4' OR OVER 20'
- 2- ENCASEMENT TO BE PLACED AGAINST UNDISTURBED NATURAL GROUND OR FILL COMPACTED TO 90% RELATIVE DENSITY
- 3- NO. 4 STEEL REINFORCING BARS SHALL BE USED AS SPECIFIED.
- 4- UNLESS NOTED OTHERWISE, ENCASEMENT SHALL BE CLASS "B" CONCRETE.
- 5- WHERE SLOPED TRENCHES ARE USED, WALLS WILL NOT BEGIN TO SLOPE CLOSER THAN 12" FROM THE TOP OF THE PIPE.
- 6- DUCTILE IRON PIPE MAY BE PERMISSIBLE IN LIEU OF CONCRETE ENCASEMENT AS APPROVED BY THE ENGINEER.

APPROVED BY
DISTRICT
ENGINEER

DATE
11/2007



MARINA COAST WATER DISTRICT STANDARD PLAN

CONCRETE ENCASEMENT

STANDARD

S-8

SHEET 1 OF 1

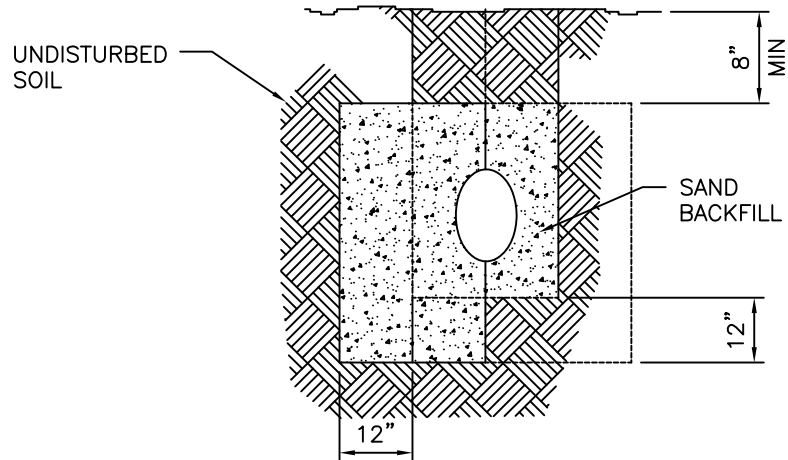
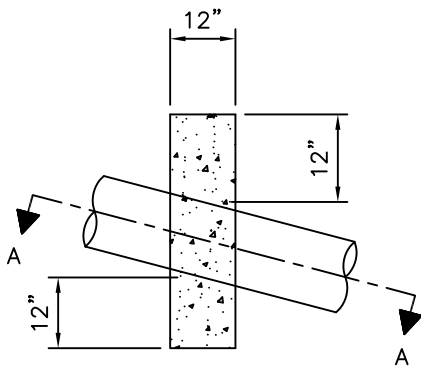
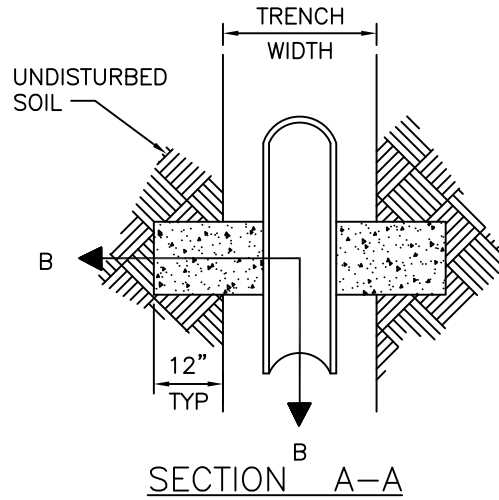
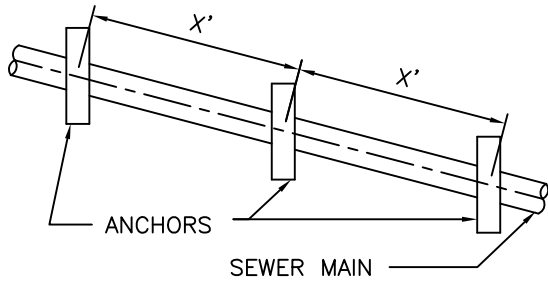

3" MIN. CLEARANCE BETWEEN REINFORCING STEEL AND EDGE OF CONCRETE

SECTION B-B

PIPE SLOPE	PIPE SLOPE	X DISTANCE
100%	1:1	12'
66.6%	1-1/2:1	14'
50%	2:1	16'
40%	2-1/2:1	18'
33.3%	3:1	20'

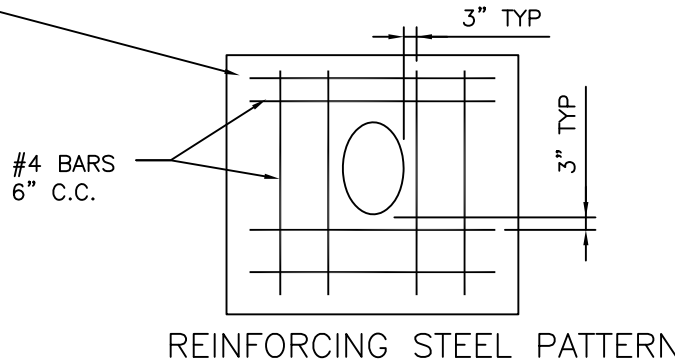

NOTES:

- 1- PIPE ANCHORS REQUIRED ON ALL SLOPES OF 2:1 OR STEEPER
- 2- ANCHOR SHALL EXTEND 12" INTO NATURAL UNDISTURBED SOIL
- 3- CONCRETE SHALL BE CLASS "A".
- 4- ANCHORS FOR TRAPAZOIDAL TRENCH SECTIONS WILL CONFORM TO TRENCH CROSS SECTION AND EXTEND 12" INTO UNDISTURBED SOIL

APPROVED BY
DISTRICT
ENGINEER

DATE

11/2007



MARINA COAST WATER DISTRICT STANDARD PLAN

CONCRETE SLOPE ANCHORS

STANDARD

S-9

SHEET 1 OF 1

P.V.C. SIZE	MIN. CASING SIZE	MIN. WALL THICKNESS.
6"	12" I.D.	1/4"
8"	16" I.D.	1/4"
10"	18" I.D.	5/16"
12"	20" I.D.	5/16"

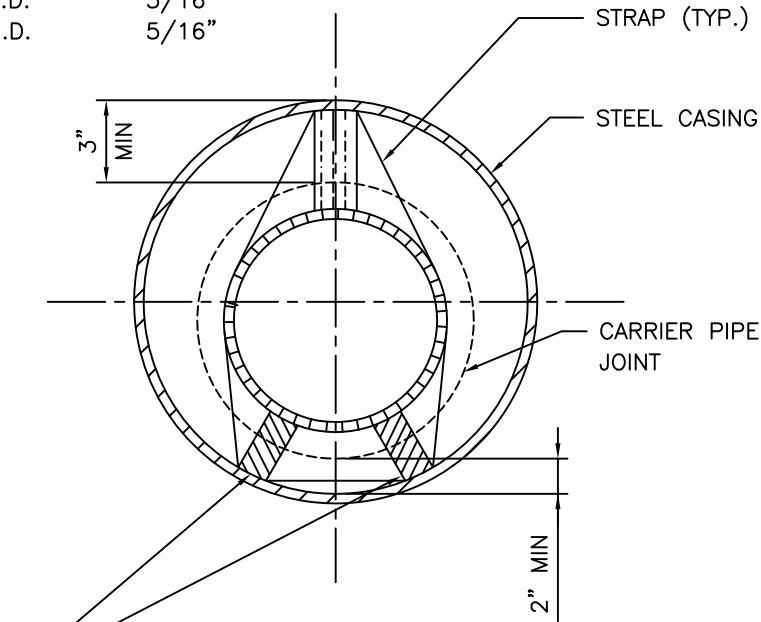

FOR EACH LENGTH OF PIPE, 3' LONG 4" X 4" POLYETHYLENE SKIDS BEVELED AT BOTH ENDS, SHALL BE STRAPPED IN PLACE 3" FROM EACH END OF PIPE. NOTCH REDWOOD SKID TO SEAT STRAP. STRAP SHALL BE 316 STAINLESS STEEL.

NOTES:

- 1- UNLESS NOTED OTHERWISE, CASING SHALL BE INSTALLED BY THE BORE, JACK AND/OR TUNNEL METHOD. IF OPEN-CUT INSTALLATION OF CASING IS ALLOWED, BACKFILL SHALL BE IN ACCORDANCE WITH MCWD STD. PLAN S-4.
- 2- SIZE AND THICKNESS OF CASING SHALL BE AS SHOWN IN SCHEDULE.
- 3- ALL STEEL CASING PIPE FIELD JOINTS SHALL BE WELDED FULL-CIRCUMFERENCE.
- 4- 4"x4" POLYETHYLENE SKIDS SHALL BE PROVIDED PER DETAIL ABOVE.
- 5- CARRIER PIPE SHALL BE AIR PRESSURE TESTED PRIOR TO FILLING CASING.
- 6- UPSTREAM AND DOWNSTREAM ELEVATIONS OF CARRIER PIPE TO BE VERIFIED PRIOR TO FILLING.
- 7- EACH END OF CASING SHALL BE MANUFACTURER SEALS (PER SPECIFICATIONS)
- 8- CASING PIPE DESIGN SHALL BE SUBMITTED TO THE DISTRICT ENGINEER FOR APPROVAL.
- 9- THESE ARE MINIMUM REQUIREMENTS. IF OTHER JURISDICTIONS REQUIREMENTS ARE MORE STRINGENT, THOSE REQUIREMENTS WILL DICTATE.

APPROVED BY
DISTRICT
ENGINEER



DATE
11/2007

MARINA COAST WATER DISTRICT STANDARD PLAN

STEEL CASING PIPE

STANDARD

S-10

SHEET 1 OF 1

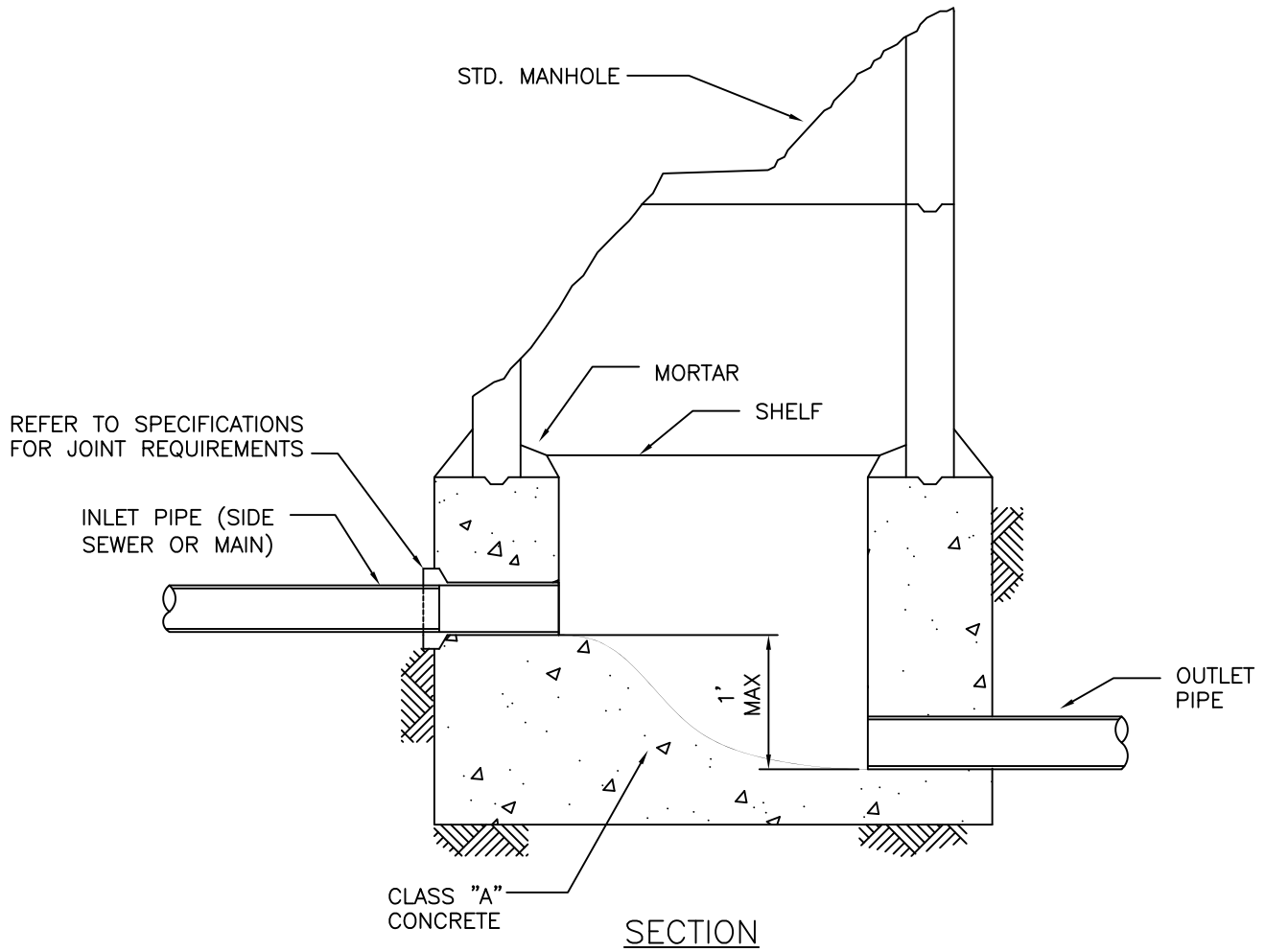

NOTES:

- 1- ALL NEW OPENINGS CONSTRUCTED INTO MANHOLE SHALL BE DONE BY CORE DRILLING
- 2- INTERIOR WALL OF MANHOLE TO BE LINED WITH PVC LINER PER SPECIFICATIONS
- 3- DEEPER DROPS REQUIRE SPECIAL DESIGN AND APPROVAL

APPROVED BY
DISTRICT
ENGINEER

DATE
11/2007



MARINA COAST WATER DISTRICT STANDARD PLAN

ALLOWABLE DROP IN MANHOLE

STANDARD

S-11

SHEET 1 OF 1

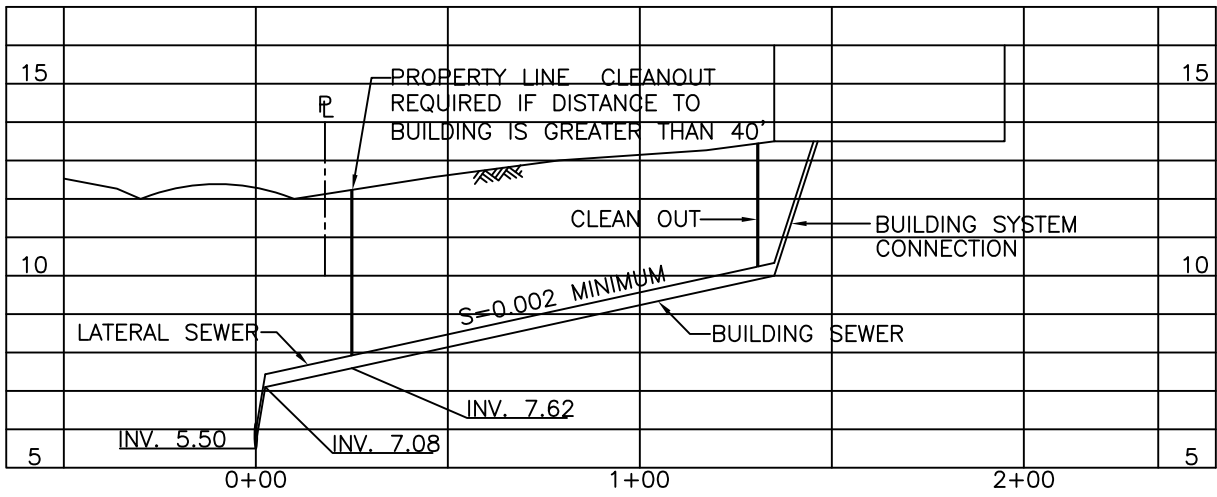
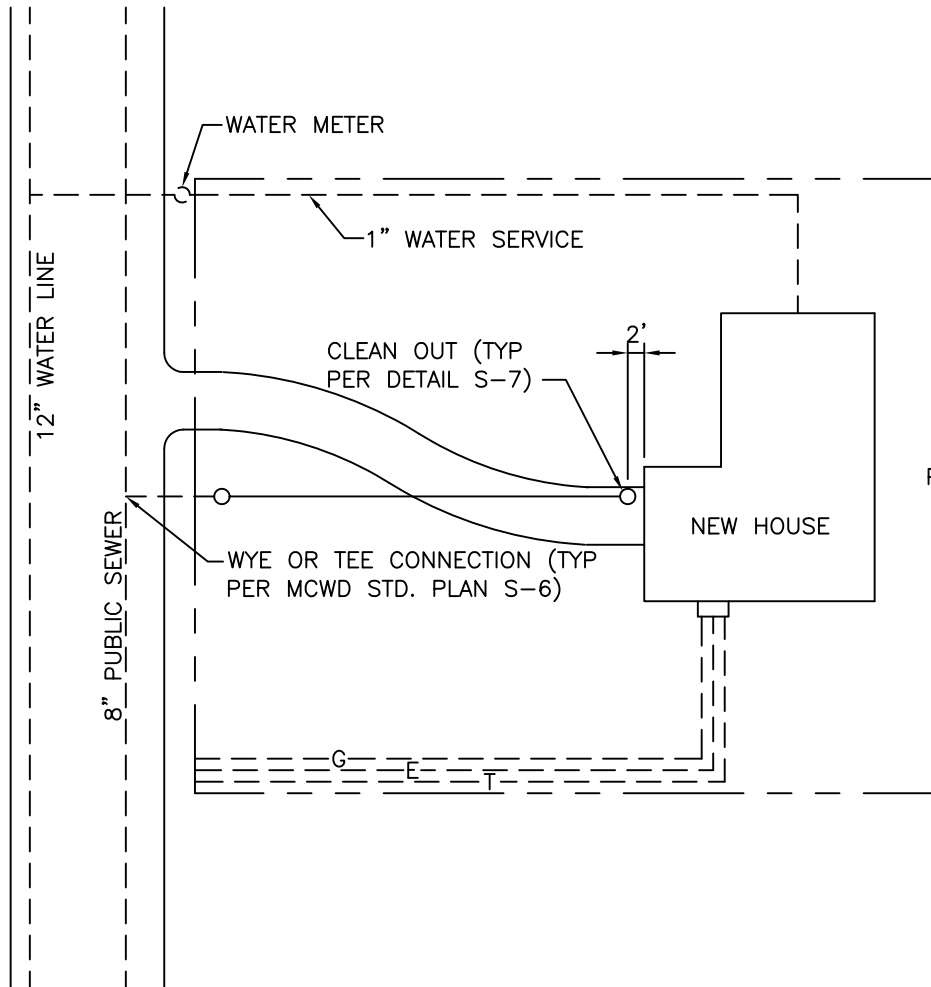

APPROVED BY DISTRICT ENGINEER		MARINA COAST WATER DISTRICT STANDARD PLAN	STANDARD
DATE 11/2007		SAMPLE BUILDING SEWER PLAN AND PROFILE	S-12
		SHEET 1 OF 1	

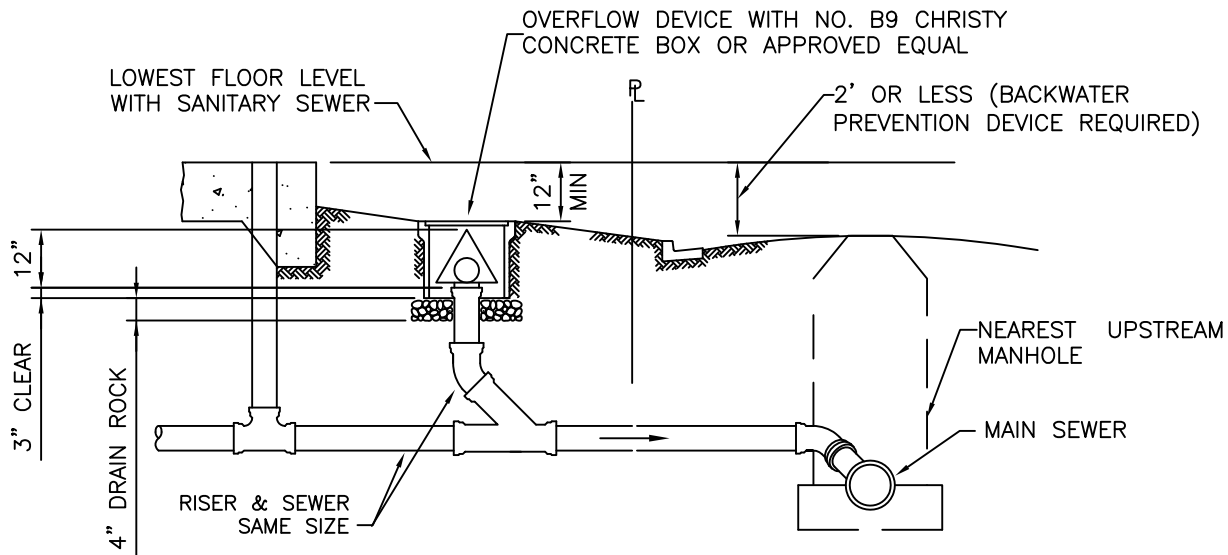

TYPICAL CLEANOUT AND OVERFLOW DEVICE

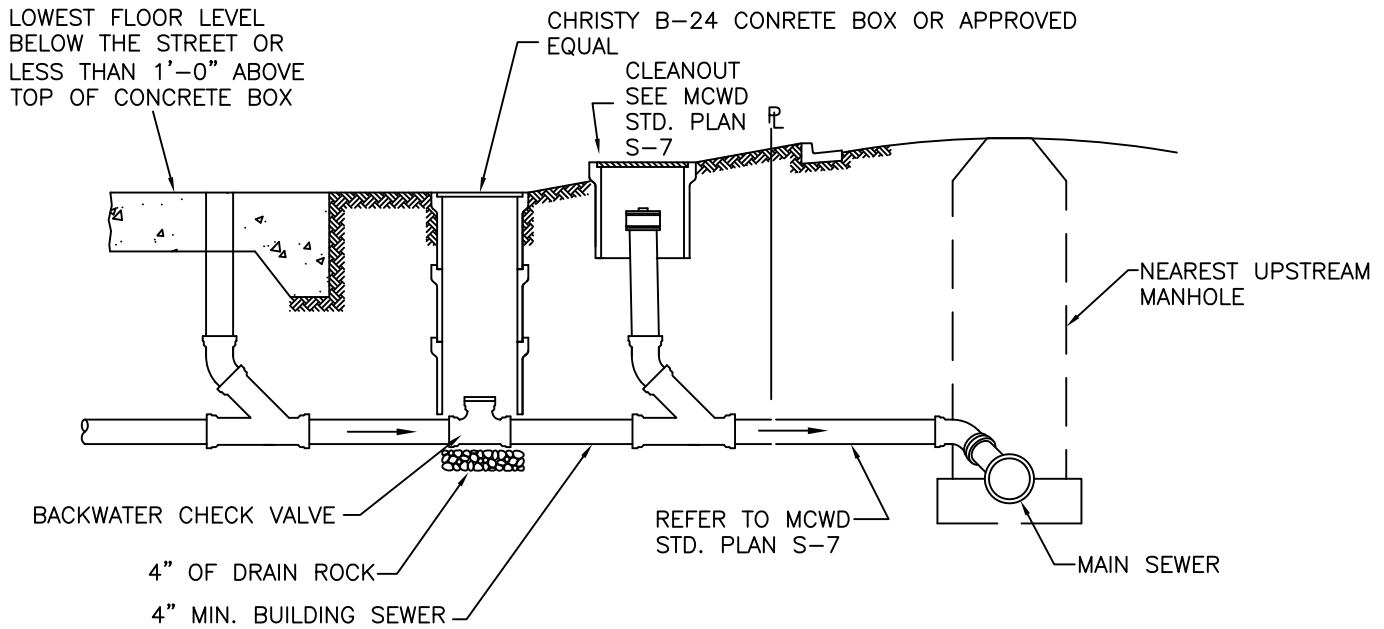

BACKWATER VALVE

NOTES:

- 1- EVERY BUILDING SEWER SHALL HAVE AN OVERFLOW DEVICE AND/OR BACKWATER VALVE INSTALLED IN THE SEWER LATERAL SERVING THE BUILDING. COMBINATION BACKWATER VALVE/CLEAN-OUT IS ALLOWED.
- 2- OVERFLOW DEVICES SHALL BE INSTALLED ON ALL LATERALS; HOWEVER BACKWATER VALVES SHALL BE INSTALLED (A) WHEN BACKWATER PROTECTION IS REQUIRED, (B) WHEN THE LOWEST FLOOR LEVEL IS BELOW THE STREET OR LESS THAN 1 FOOT ABOVE THE TOP OF THE CONCRETE BOX CONTAINING THE OVERFLOW DEVICE, OR (C) SEWAGE CANNOT BE ALLOWED TO OVERFLOW ON THE SURROUNDING AREA.
- 3- AN OVERFLOW DEVICE OR A BACKWATER VALVE MAY BE WAIVED WHEN THE LOWEST FLOOR LEVEL TO BE SEWERED IS MORE THAN 2 FEET ABOVE THE RIM OF THE NEAREST UPSTREAM MANHOLE AND IN THE OPINION OF THE DISTRICT SUCH INSTALLATION IS UNNECESSARY FOR PROTECTION OR FOR HEALTH AND SAFETY REQUIREMENTS.

APPROVED BY
DISTRICT
ENGINEER

DATE

11/2007



MARINA COAST WATER DISTRICT STANDARD PLAN

BACKWATER PROTECTION

STANDARD

S-13

SHEET 1 OF 1

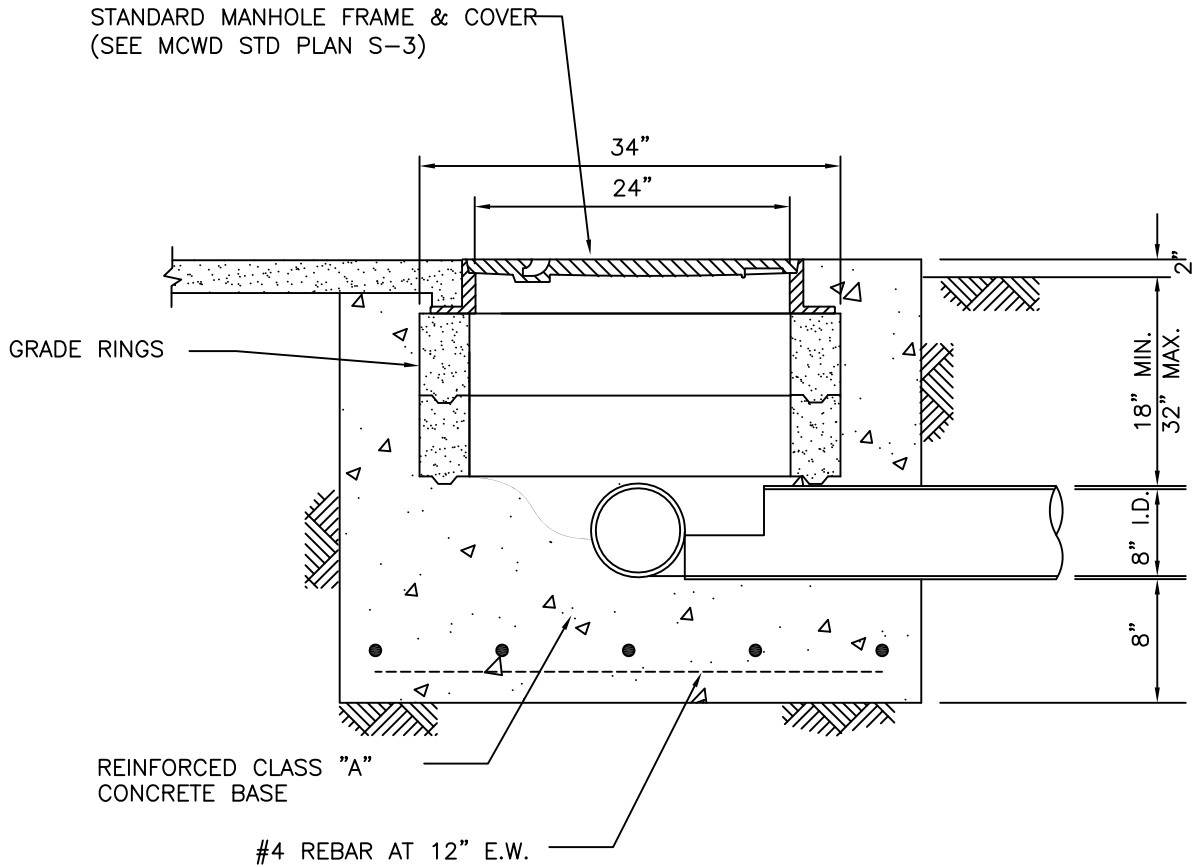

SECTION

NOTES:

- 1- SPECIAL SHALLOW MANHOLE IS USED FOR 8-INCH OR SMALLER PIPE ONLY.
- 2- SPECIAL SHALLOW MANHOLE SHALL BE USED ONLY WITH APPROVAL OF DISTRICT ENGINEER

APPROVED BY
DISTRICT
ENGINEER

DATE
11/2007



MARINA COAST WATER DISTRICT STANDARD PLAN

SPECIAL SHALLOW MANHOLE

STANDARD

S-14

SHEET 1 OF 1

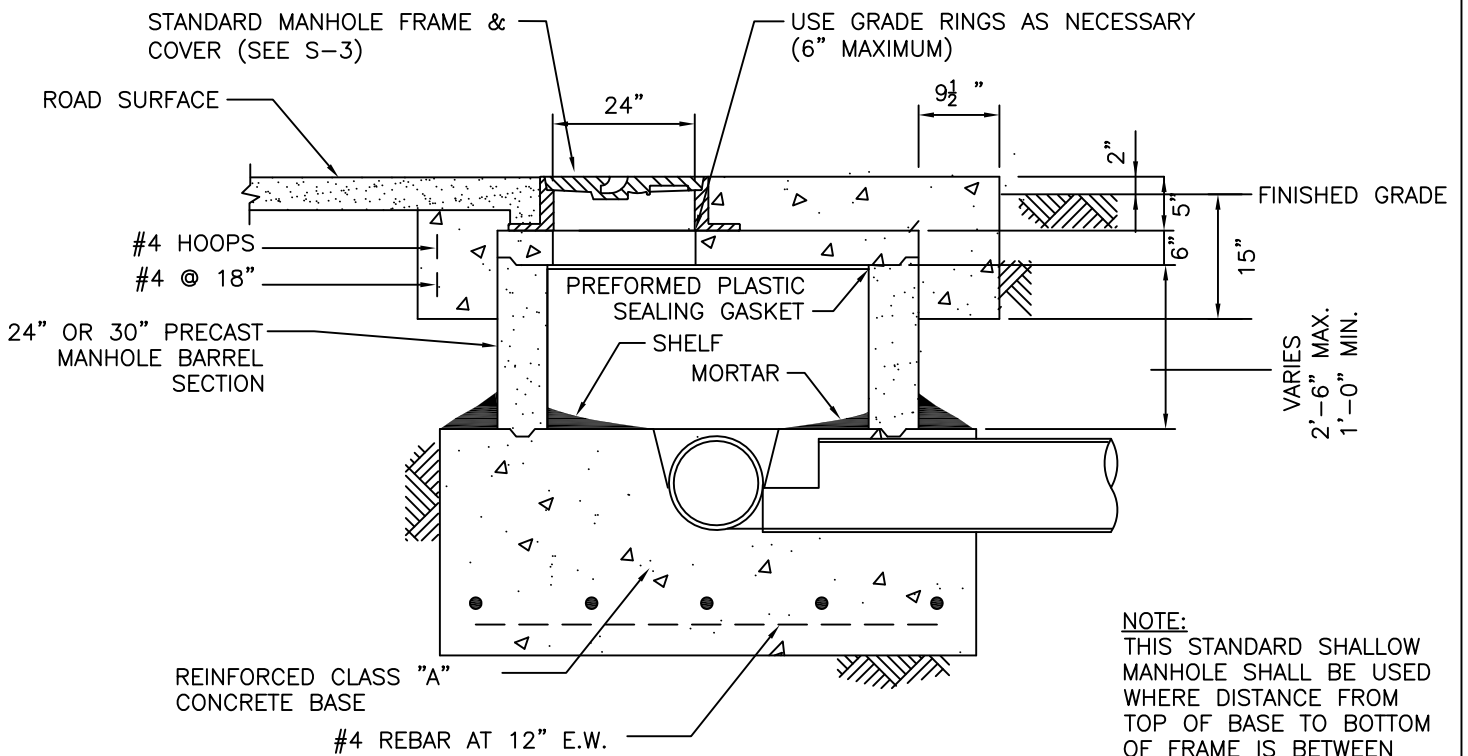

SECTION

BETWEEN 36" & 54" (RIM TO FLOWLINE)

NOTE:
THIS STANDARD SHALLOW MANHOLE SHALL BE USED WHERE DISTANCE FROM TOP OF BASE TO BOTTOM OF FRAME IS BETWEEN 18" AND 36", WITH APPROVAL FROM THE DISTRICT.

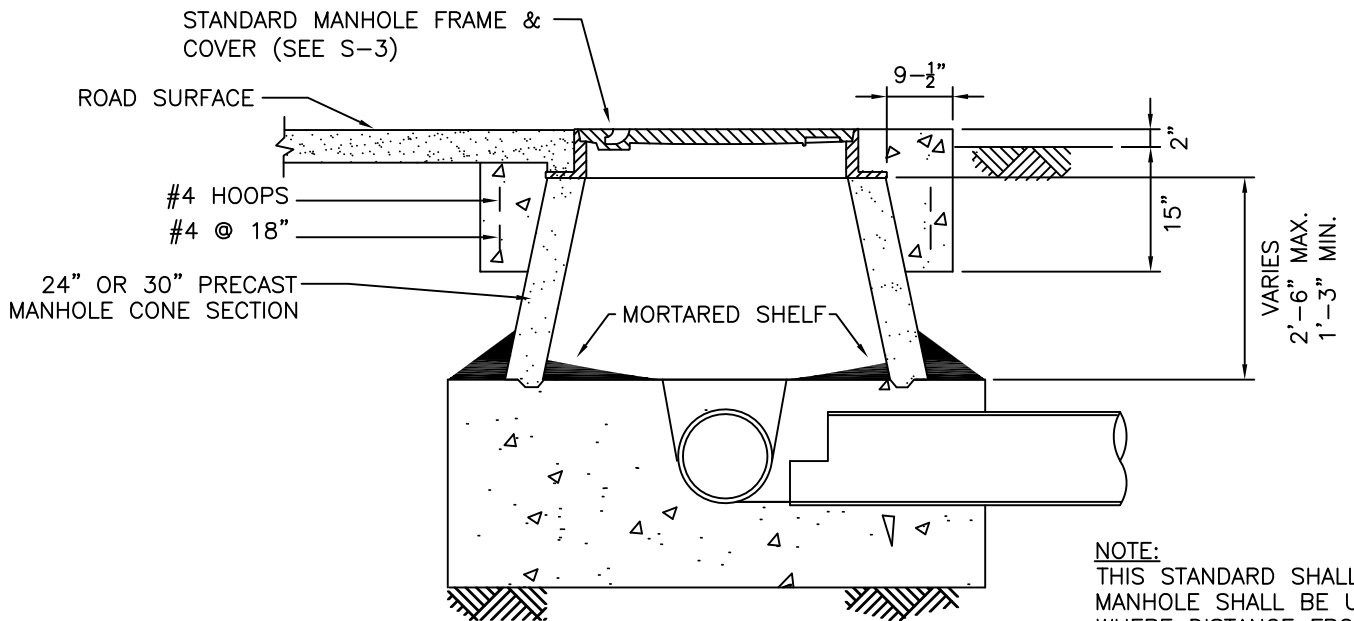

SECTION

BETWEEN 32" & 47" (RIM TO FLOWLINE)

NOTE:
THIS STANDARD SHALLOW MANHOLE SHALL BE USED WHERE DISTANCE FROM TOP OF BASE TO BOTTOM OF FRAME IS BETWEEN 15" AND 30", WITH APPROVAL FROM THE DISTRICT.

APPROVED BY
DISTRICT
ENGINEER

DATE

11/2007



MARINA COAST WATER DISTRICT STANDARD PLAN

STANDARD SHALLOW MANHOLES

STANDARD

S-15

SHEET 1 OF 1

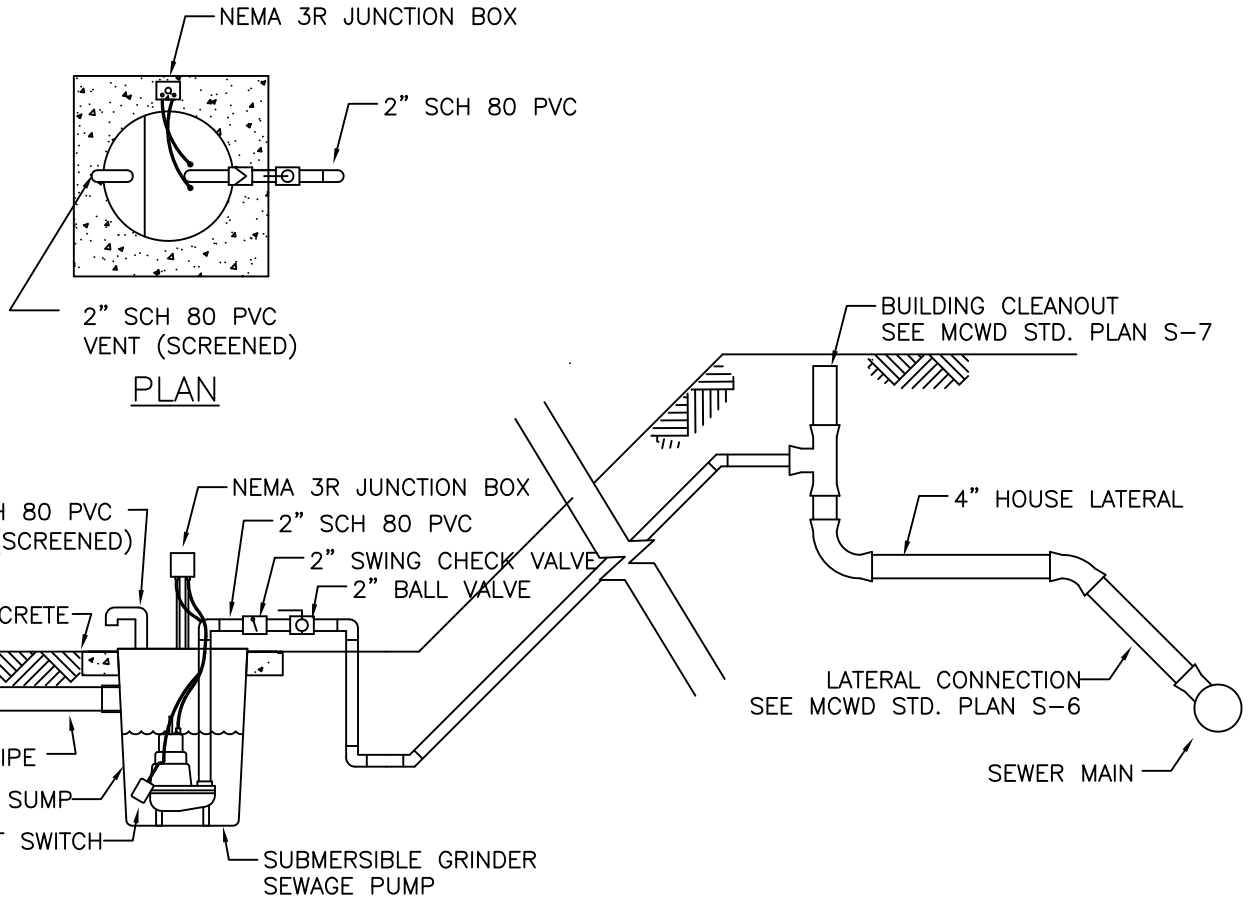

NOTES:

ELEVATION

GENERAL: THE MINIMUM REQUIREMENTS FOR A RESIDENTIAL SEWAGE PUMP STATION CONNECTION A SINGLE RESIDENCE OR EQUIVALENT TO THE DISTRICT'S SYSTEM ARE SPECIFIED IN THE FOLLOWING NOTES. THE DISTRICT ACCEPTS NO RESPONSIBILITY FOR THE DESIGN, OPERATION OR MAINTENANCE OF SUCH PRIVATELY OWNED AND OPERATED SYSTEMS.

ALL EQUIPMENT AND ACCESSORIES SHALL BE STANDARD MANUFACTURED ITEMS AND THOSE COMING IN DIRECT CONTACT WITH SEWAGE SHALL BE SPECIFICALLY MANUFACTURED FOR SEWAGE USE.

WHEN INSTALLED OUTSIDE OF A BUILDING, THE MOTOR AND CONTROLS SHALL BE PROTECTED AND SHELTERED BY A WEATHER-PROOF, WELL VENTILATED ENCLOSURE.

WHEN SURCHARGE HEAD IS DEEMED EXCESSIVE, THE DISTRICT SHALL MAY REQUIRE A PRESSURE RELIEF STRUCTURE.

PUMPS: RAW SEWAGE PUMPS SHALL BE USED ON ALL NEW CONSTRUCTION AND MAY BE USED ON EXISTING FACILITIES. PUMP SHALL BE A SUBMERSIBLE VERTICAL ENCLOSED SHAFT OF PROPER LENGTH TO FIT THE PUMP SUMP AND SHALL HAVE A MINIMUM CAPACITY OF 45-GALLONS PER MINUTE WHEN PUMPING AGAINST THE REQUIRED HEAD, AS CALCULATED BY THE ENGINEER.

THE IMPELLER SHALL BE CAPABLE OF PASSING A 2-INCH SPHERE. THE MINIMUM PUMP DISCHARGE SHALL BE 3-INCH IN DIAMETER.

IF A GARBAGE DISPOSAL UNIT IS TO BE CONNECTED, THE PUMP CAPACITY SHALL BE INCREASED TO A MINIMUM OF 75 GPM WHEN PUMPING AGAINST THE REQUIRED HEAD AS CALCULATED BY THE ENGINEER. THE MINIMUM PUMP DISCHARGE SHALL BE 4-INCHES IN DIAMETER.

IF GRINDER PUMPS ARE USED, THE MINIMUM PUMP DISCHARGE SHALL BE 2-INCHES IN DIAMETER. PUMP CAPACITY SHALL BE AS REQUIRED ABOVE.

COMMERCIAL INSTALLATIONS SHALL CONSIST OF 4-INCH DUPLEX PUMPS EACH RATED FOR TOTAL LOADING. EFFLUENT SEWAGE PUMP MAY BE USED WITH EXISTING SEPTIC TANK INSTALLATIONS ONLY. THE PUMP SHALL BE A SUMP OR BILGE TYPE WITH A VERTICAL ENCLOSED SHAFT, HAVING A MINIMUM CAPACITY OF 20 GPM WHEN PUMPING AGAINST THE REQUIRED HEAD. THE MINIMUM PUMP DISCHARGE SHALL BE 2-INCHES IN DIAMETER.

PUMP SUMP: THE PUMP SUMP SHALL BE 36-INCHES IN DIAMETER AND THE DEPTH SHALL BE AS REQUIRED TO EXTEND 6-INCHES ABOVE GRADE AND 3-FT BELOW THE INLET PIPE. IT MAY BE MADE OF THE FOLLOWING MATERIALS.

*****DOES MCWD WANT THIS HERE OR IN SPEC?*****

APPROVED BY
DISTRICT
ENGINEER



MARINA COAST WATER DISTRICT STANDARD PLAN

STANDARD

DATE

11/2007

RESIDENTIAL SEWAGE PUMP STATION

S-16

SHEET 1 OF 2

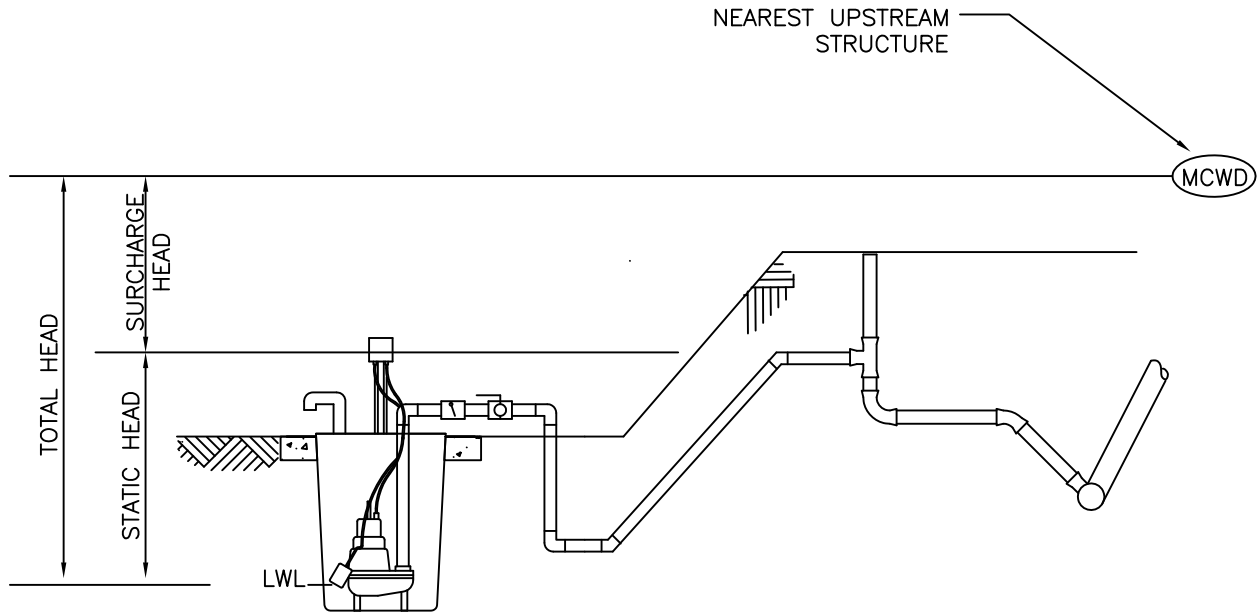

HYDRAULIC PROFILE

SEE SHT 1 FOR DETAIL LAYOUT

SYSTEM DATA:

OWNER: _____

ADDRESS: _____

SITE LOCATION: _____

SEWER CONTRACTOR: _____

DO YOU HAVE A GARBAGE DISPOSAL? _____

DO YOU HAVE A SEPTIC TANK? _____

PUMP HEAD REQUIREMENTS:

STATIC HEAD = _____ FT.

SURCHARGE HEAD = _____ FT.

FRICTION HEAD = _____ FT.

TOTAL DYNAMIC HEAD = _____ FT.

EQUIPMENT DATA:

PUMP MANUFACTURER: _____

PUMP MODEL NUMBER: _____

PUMP CAPACITY: _____ GPM @ _____ FT TDH
(ATTACH PUMP CURVE)

PUMP SIZE: _____ HP, TYPE: _____

SUMP DEPTH: _____ FT

PUMP DISCH. SIZE: _____ IN

PUMP DISCH. PASSES: _____ IN SPHERE

PUMP BRAKE HP: _____

MOTOR HP: _____ & RPM _____

MOTOR PHASE: _____ & VOLTS _____

PUMP SUMP MANUFACTURER: _____

SUMP DIAMETER X HEIGHT: _____

SUMP TANK MATERIAL: _____ COVER MATERIAL: _____

D I S T R I C T U S E O N L Y
(DO NOT WRITE BELOW THIS LINE)

DATE BY

PLOT PLAN SUBMITTED: _____

ELEVATION & DISTANCES CHECKED: _____

EQUIPMENT DATA SUBMITTED: _____

REVIEWED & APPROVED: _____

ASSOCIATE ENGINEER PLAN REVIEW: _____

APPROVED BY
DISTRICT
ENGINEER

DATE

11/2007



MARINA COAST WATER DISTRICT STANDARD PLAN

RESIDENTIAL SEWAGE PUMP STATION
DATA SHEET

STANDARD

S-16

SHEET 2 OF 2